

# caro

Led

Instructions de montage  
 Mounting instructions  
 Montageanleitung  
 Montagehandleitung



220V 50Hz  
 240V 60Hz

CE IEC  
 EN 60598



IK08 IP66

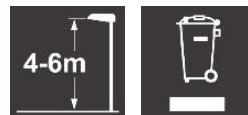

Type	LEDs	Power (W)	SCx (m <sup>2</sup> )	Weight (kg)	Type	LEDs	Power (W)	SCx (m <sup>2</sup> )	Weight (kg)
L-530-C2	16 / 32	32 / 64	0,037	7,5	L-530-R2	16 / 32	32 / 64	0,045	7,7
L-530-LD	16 / 32	32 / 64	0,026	7,1	L-530-R3	16 / 32	32 / 64	0,046	7,8
L-530-L2	16 / 32	32 / 64	0,033	7,3	L-530-RD	16 / 32	32 / 64	0,040	7,5
L-530-N2	16 / 32	32 / 64	0,049	8,0	L-530-U1	16 / 32	32 / 64	0,044	7,8

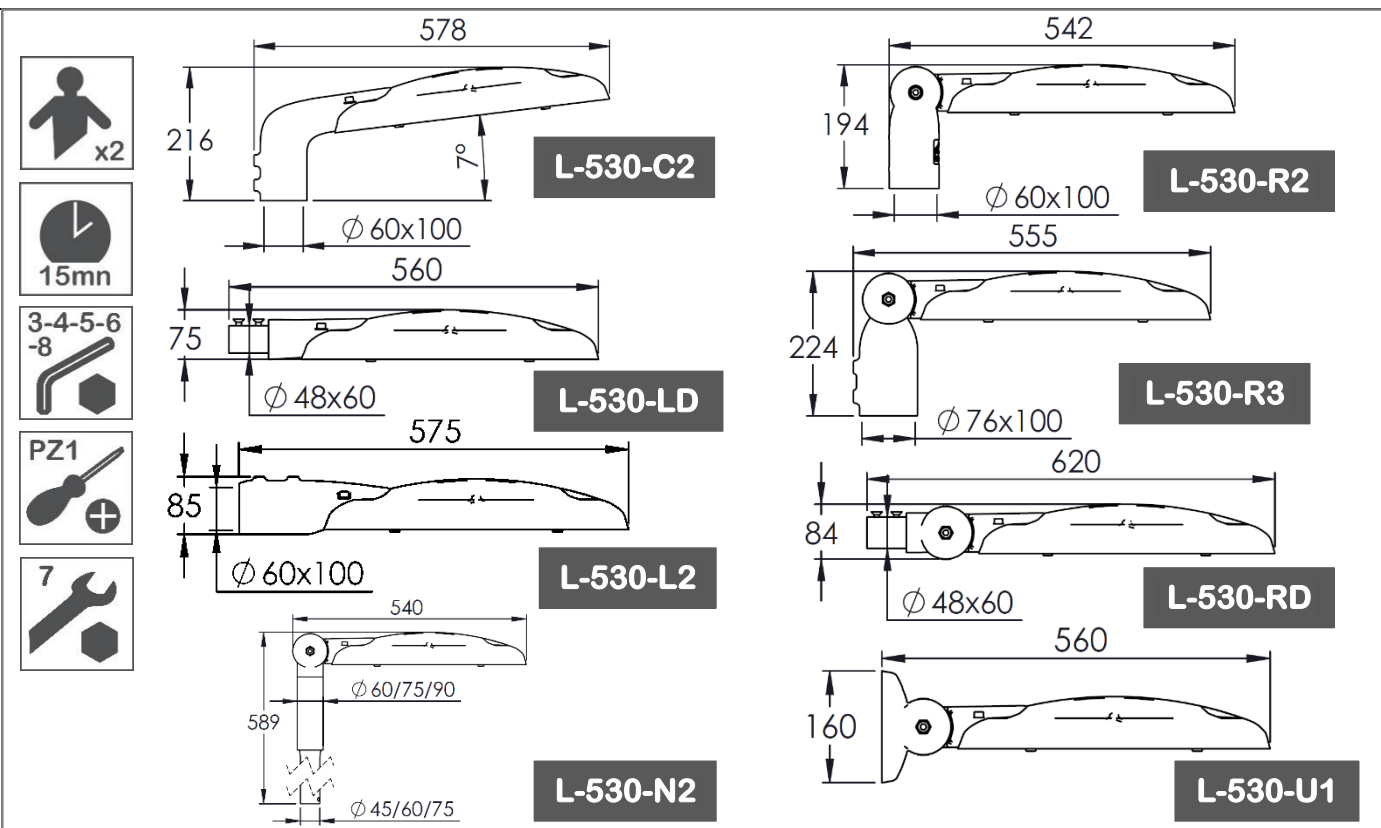



# L-530

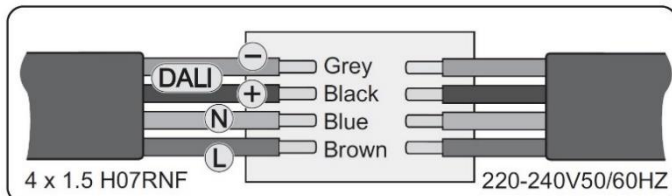

Disconnect before servicing  
Mette hors tension avant intervention  
Öffnen nur spannungsfrei  
Bij werkzaamheden aan de apparatuur

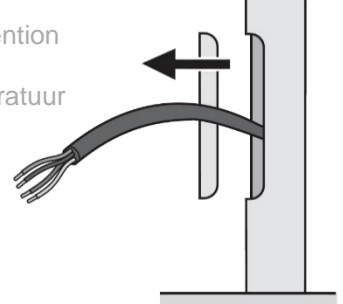
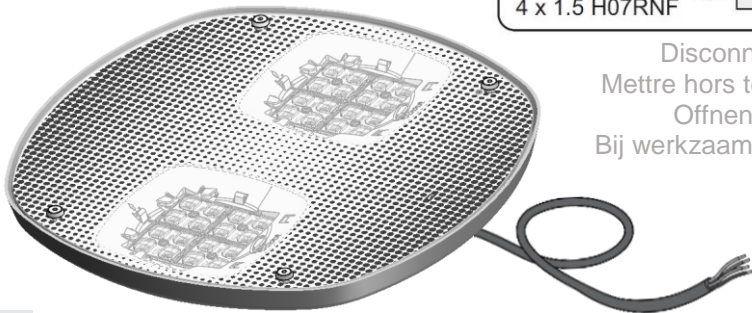

1

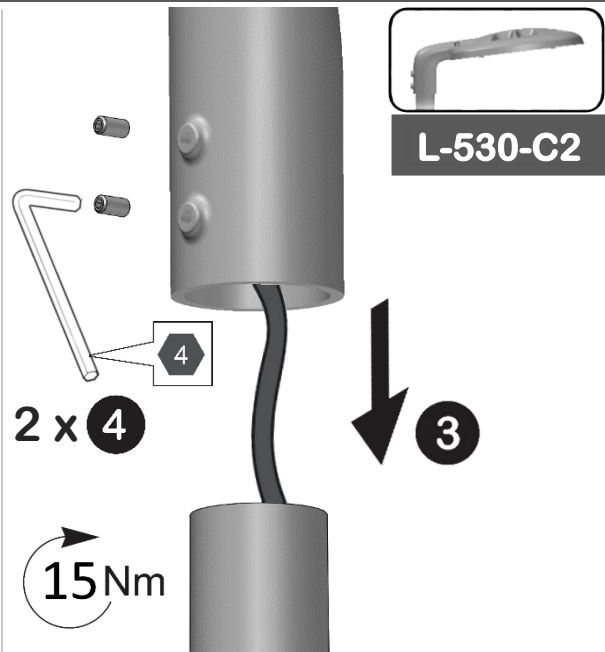
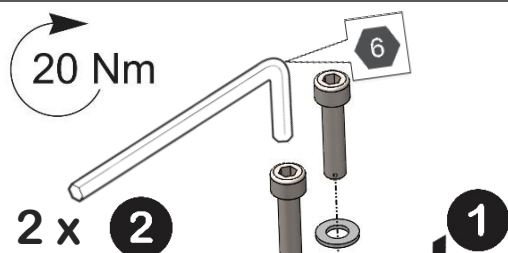

2a

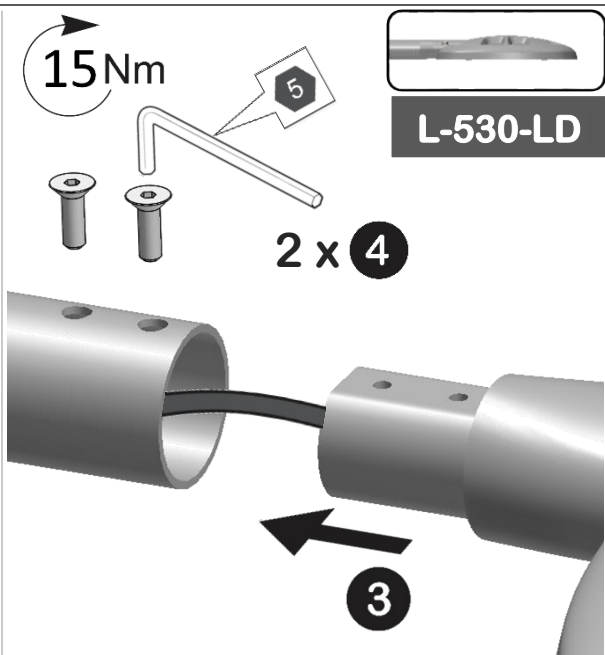
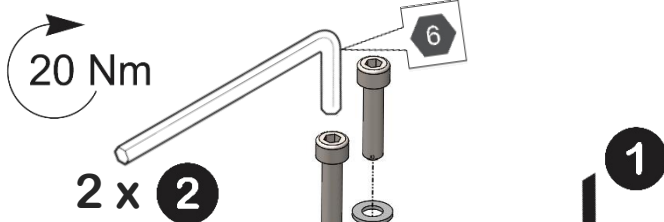

2b

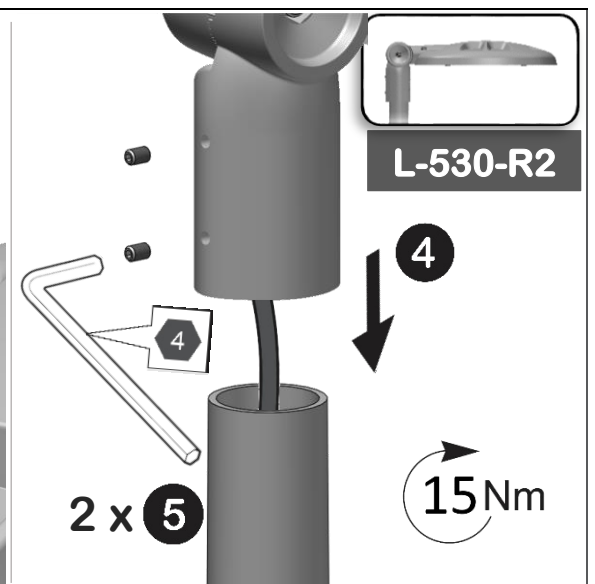
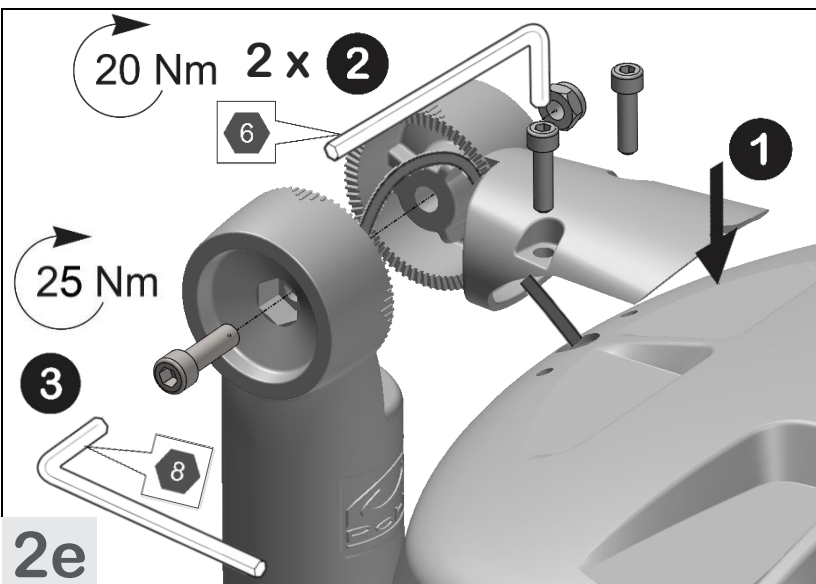
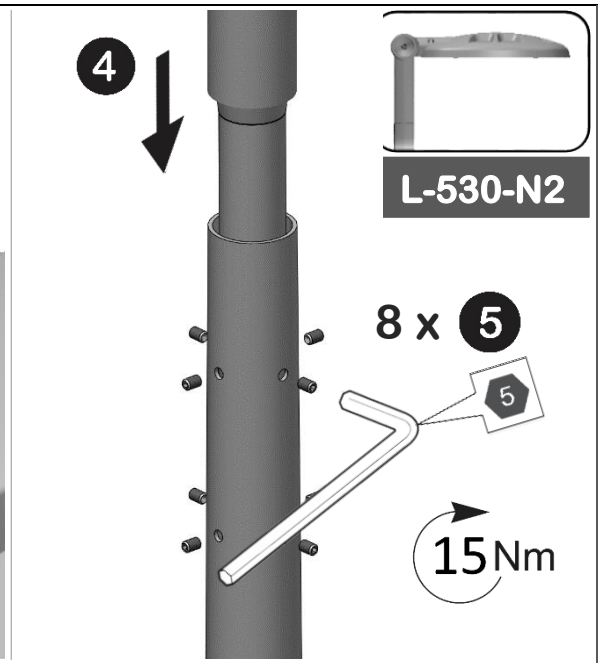
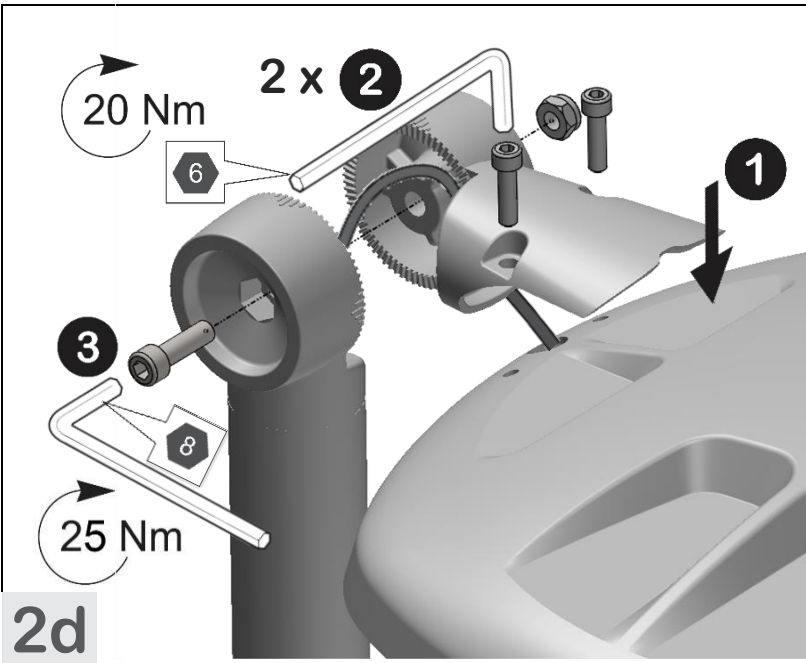
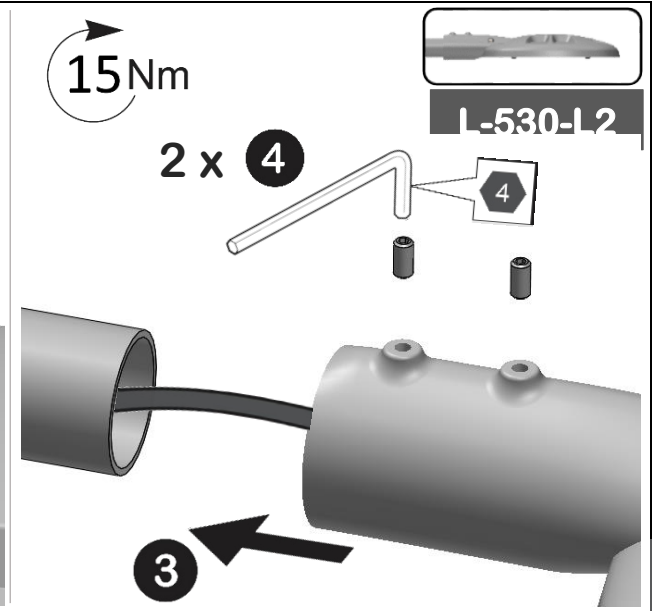
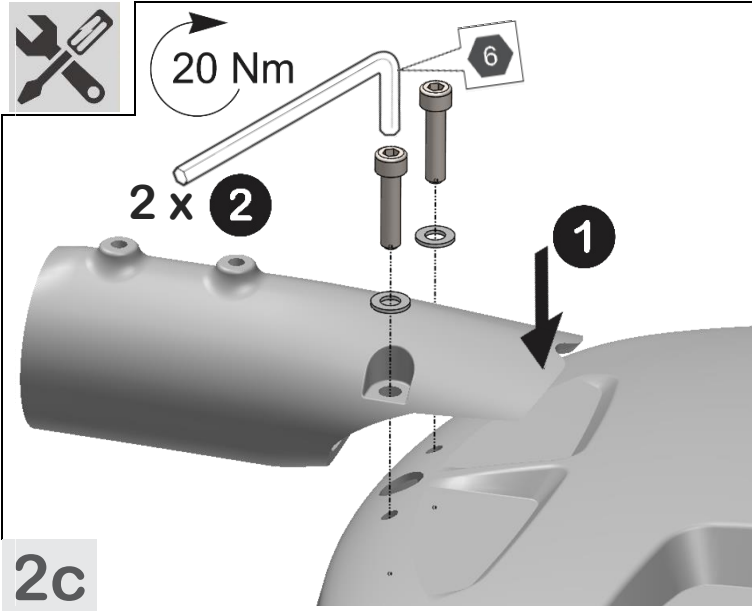

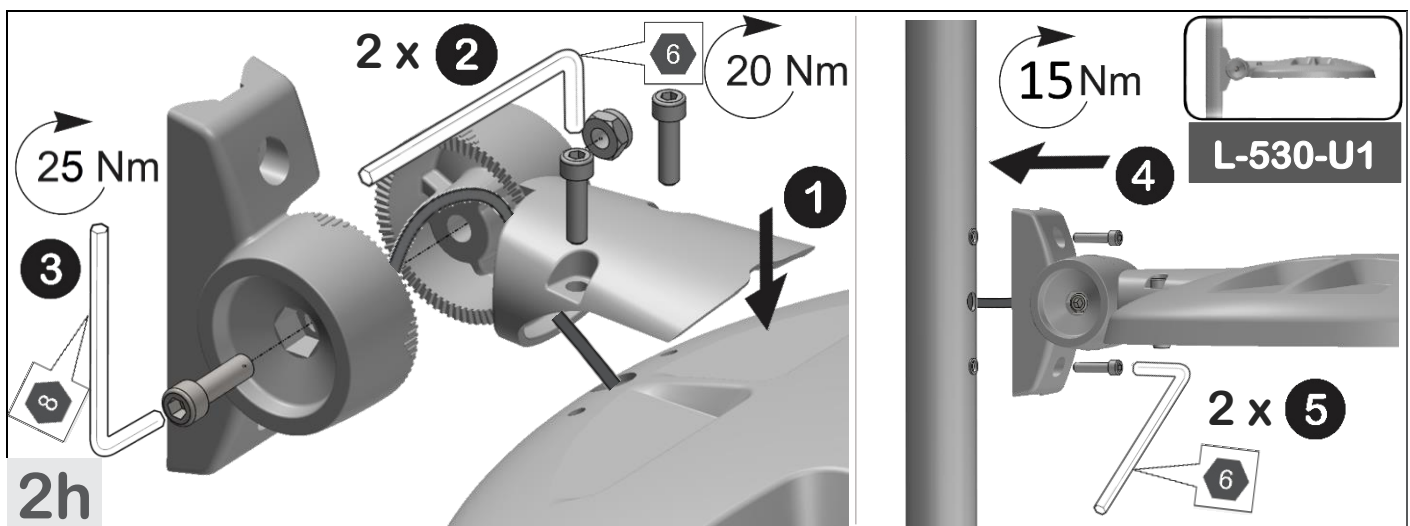
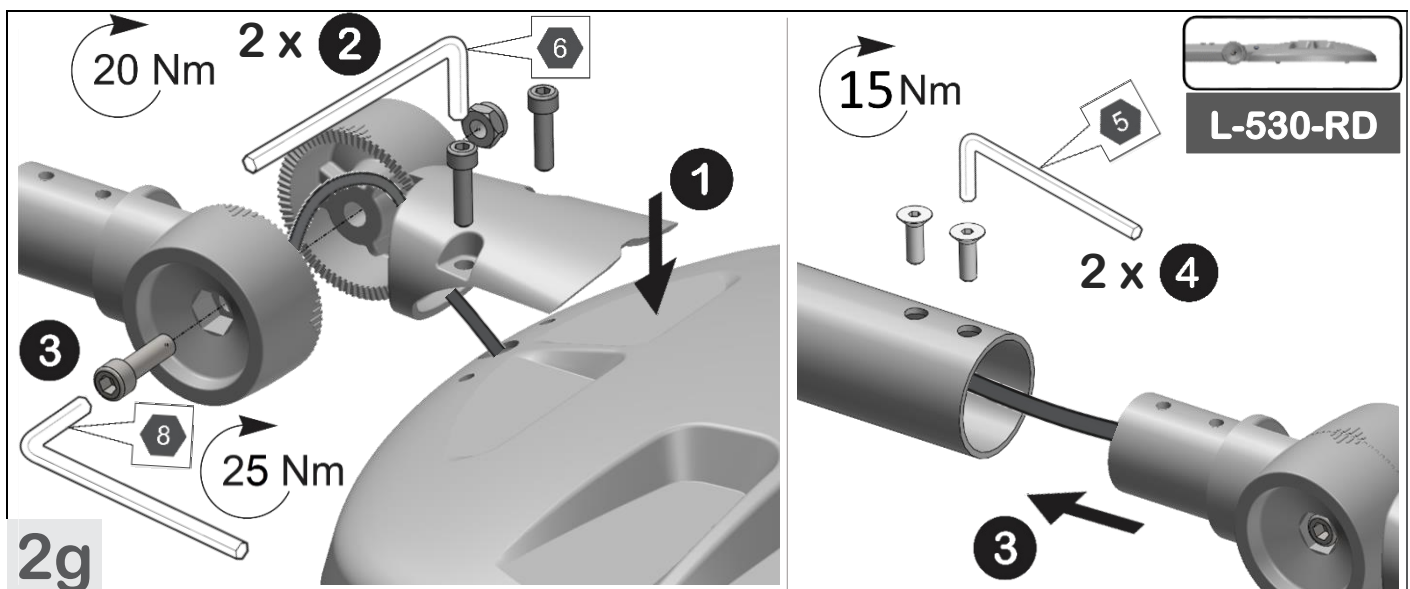
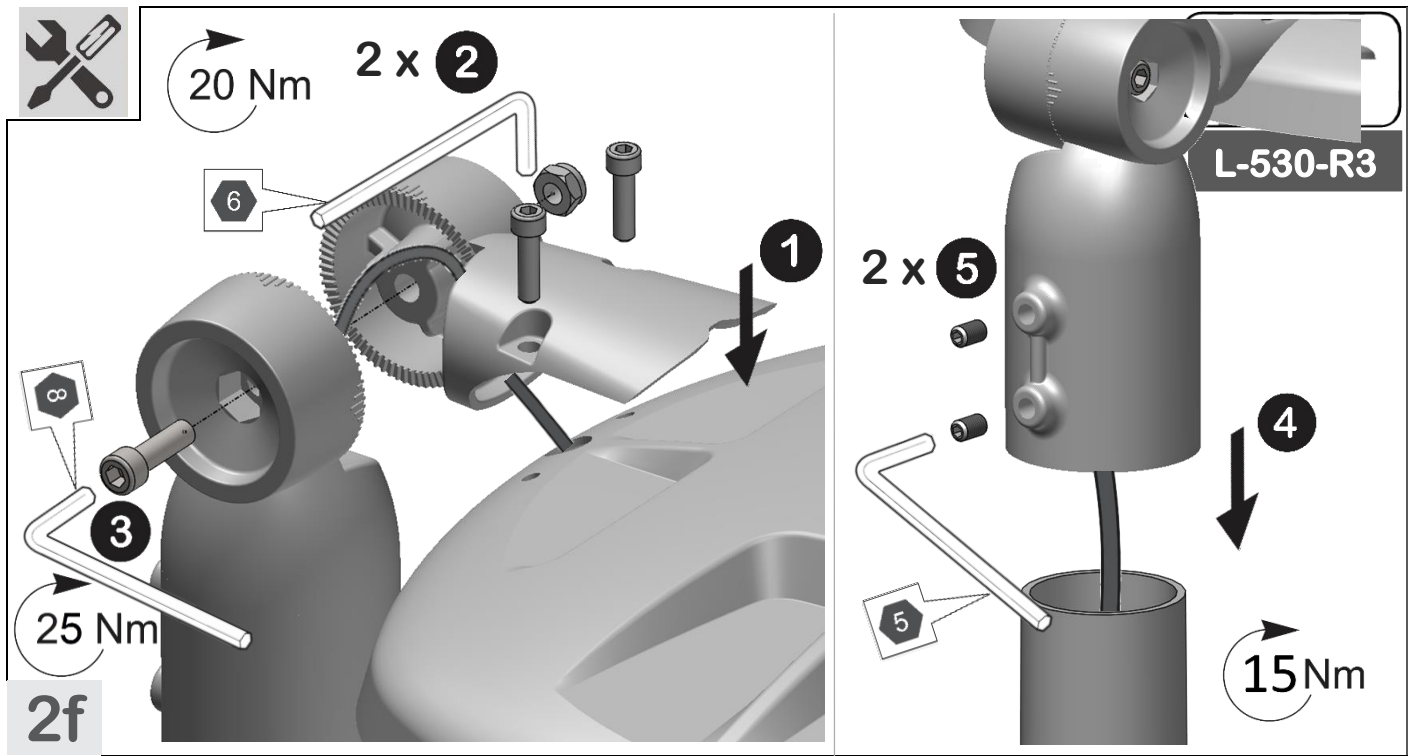



# L-530



**CAUTION**  
 Static Sensitive Devices  
 Do not open outside EDS protected area /  
 Ne pas ouvrir hors de la zone protégée ESD

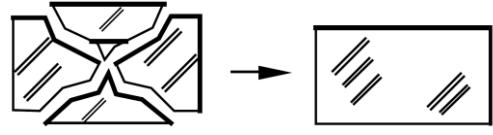
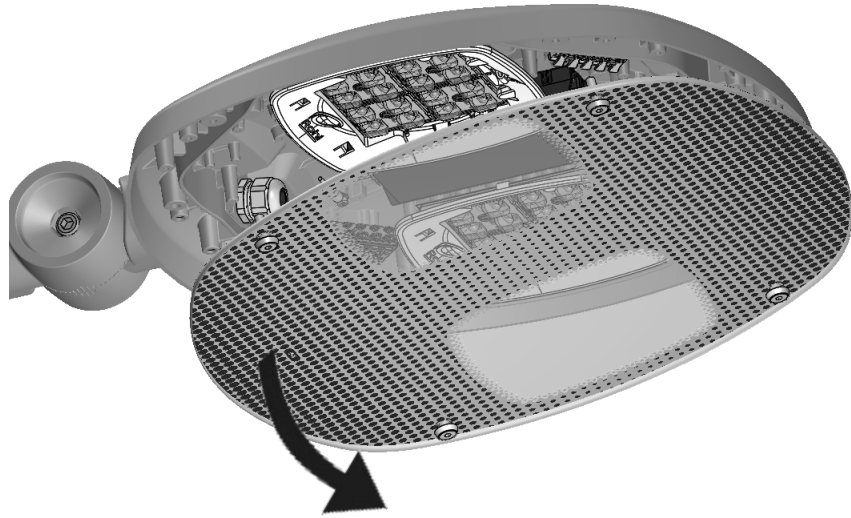
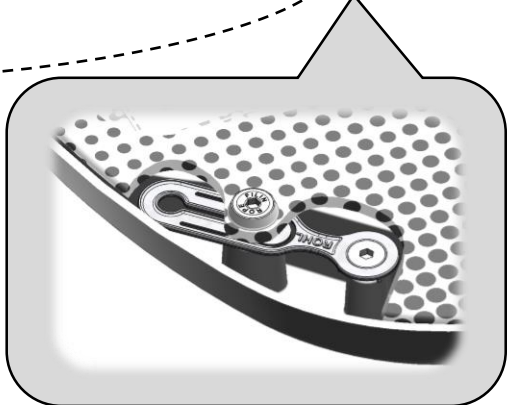
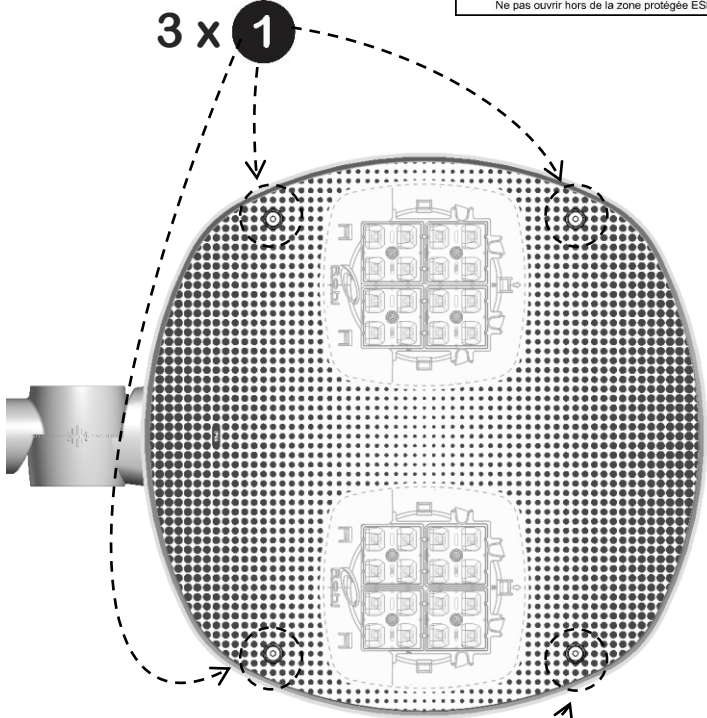
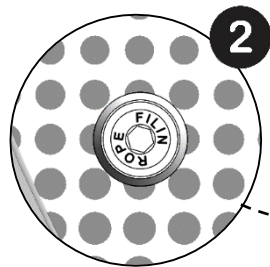
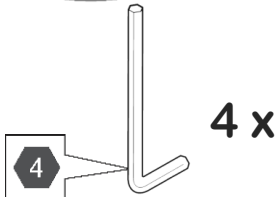
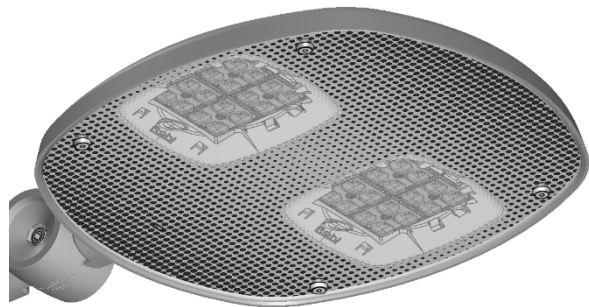

1



# L-530-LR1



**CAUTION**  
 Static Sensitive Devices  
 Do not open outside EDS protected area /  
 Ne pas ouvrir hors de la zone protégée ESD

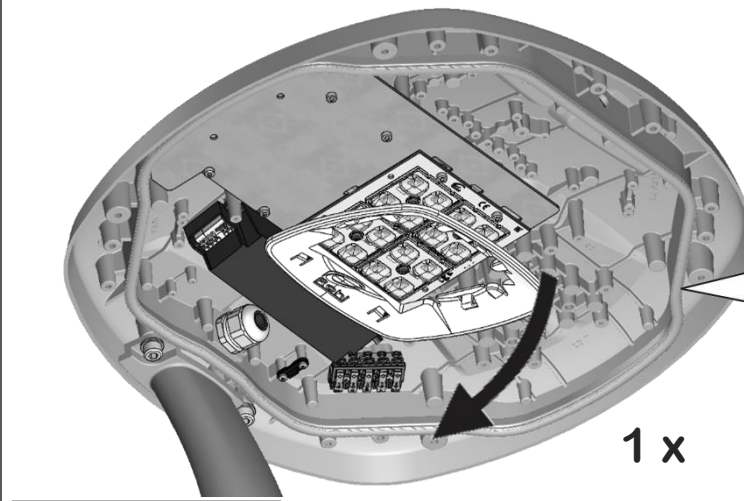

1 x

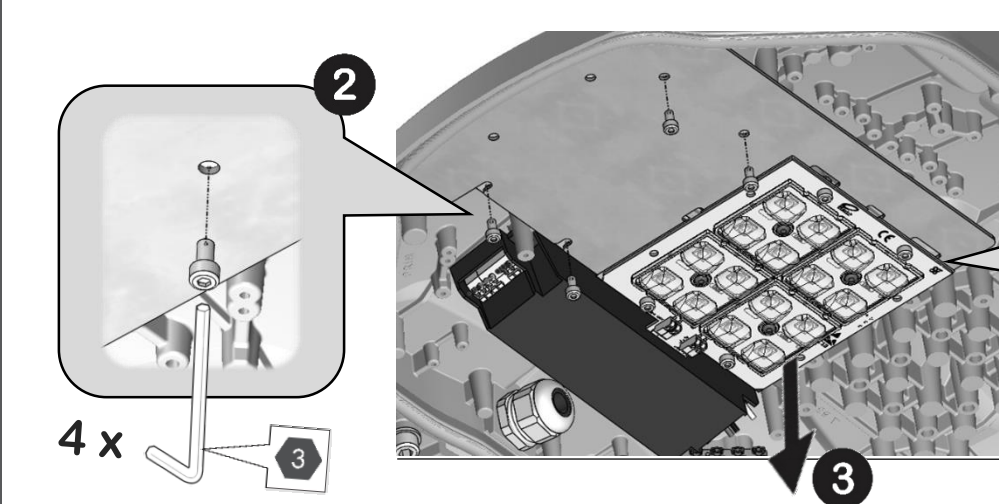
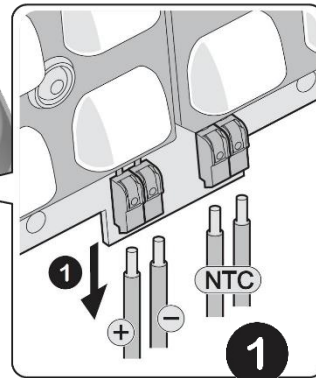

4 x

2.5 Nm

4 x

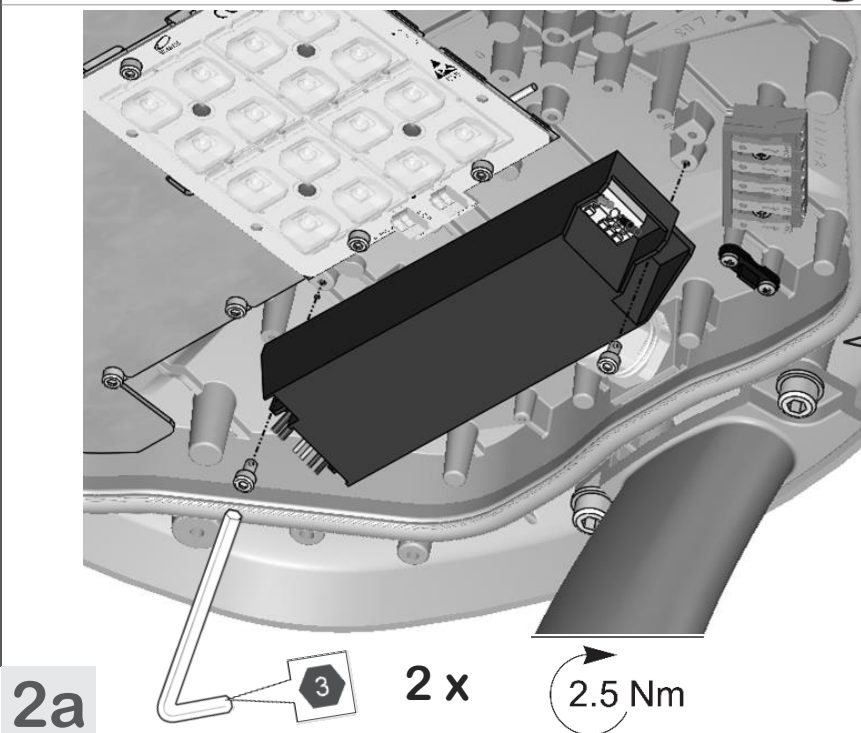

2a

2 x

2.5 Nm

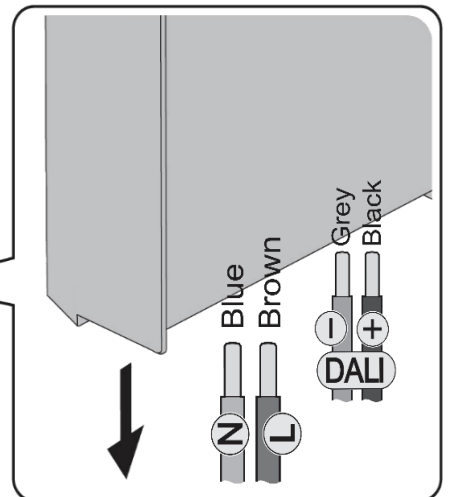



# L-530-LR2



**CAUTION**  
 Static Sensitive Devices  
 Do not open outside EDS protected area /  
 Ne pas ouvrir hors de la zone protégée ESD

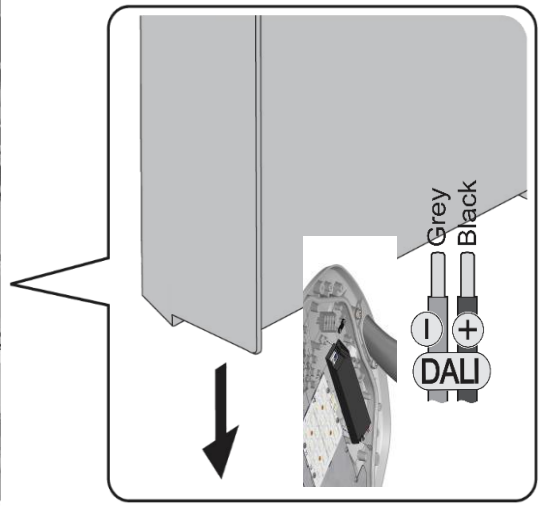
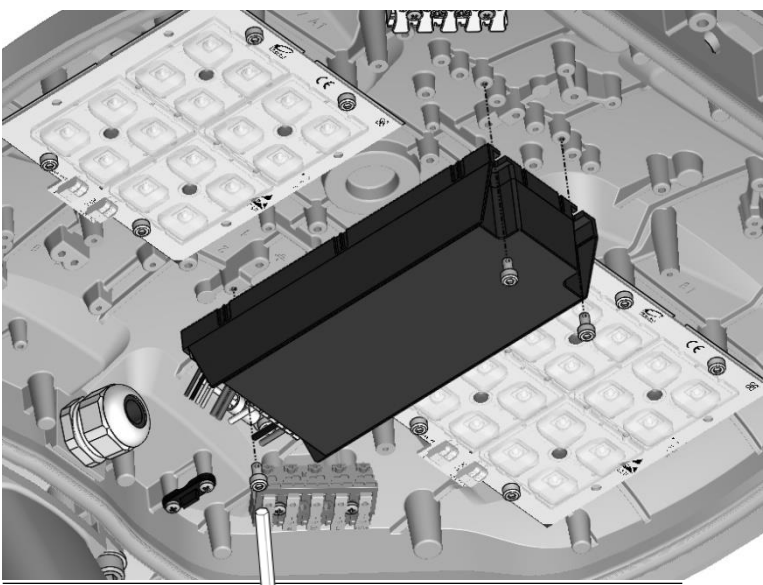
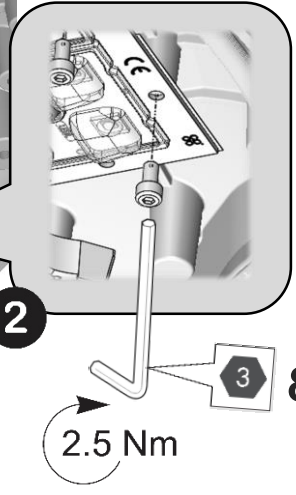
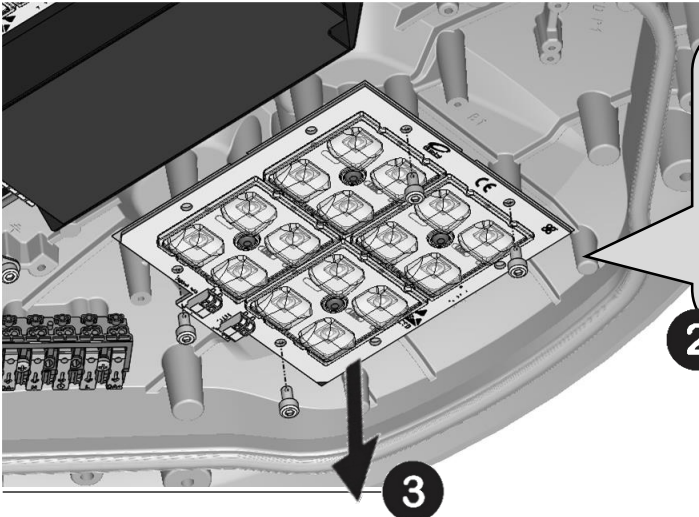
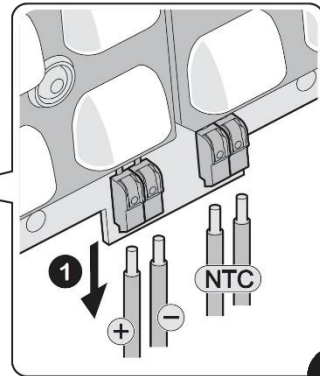
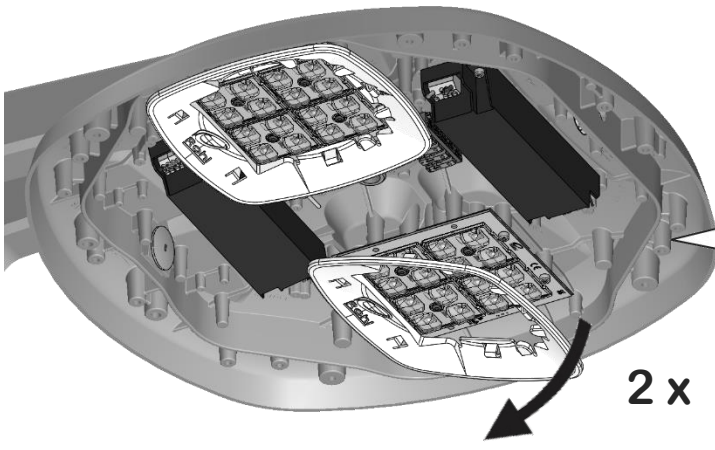

2b

2.5 Nm

3

3 x



**CAUTION**  
 Static Sensitive Devices  
 Do not open outside EDS protected area /  
 Ne pas ouvrir hors de la zone protégée ESD

**32w**  
 1xmodule R-Class  
 16 LEDs  
 4x CHC M4

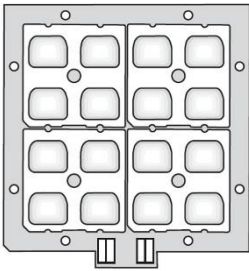

**64w**  
 2xmodule R-Class  
 32 LEDs  
 8x CHC M4

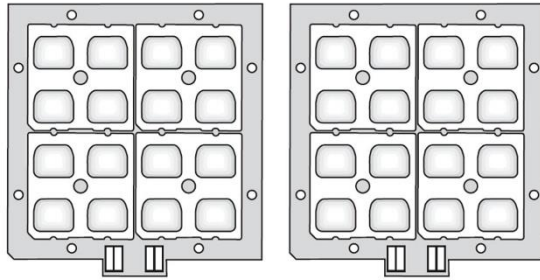

**L-530 LR1 + LR2**

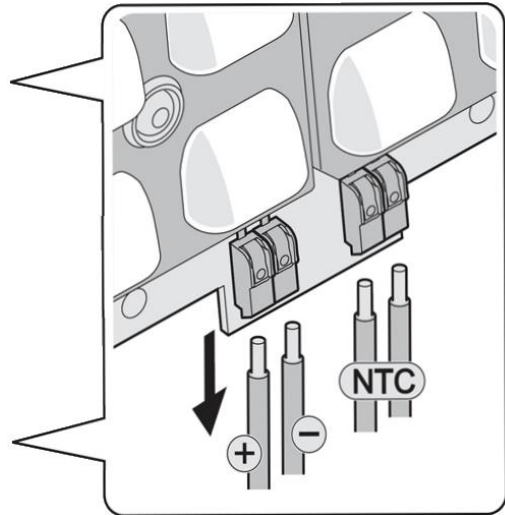

**L-530 LU2 + LU4**

**32w LU**  
 2xmodule 2x4  
 16 LEDs  
 4x CBZ M3

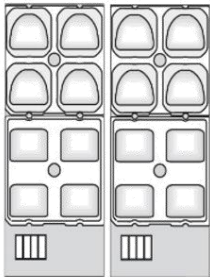

**64w LU**  
 4xmodule 2x4  
 32 LEDs  
 8x CBZ M3

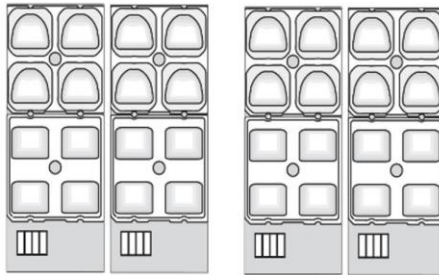











**FRA** La source de lumière intégrée dans ce luminaire peut uniquement être remplacée par un employé de Rohl, un agent ou une autre personne qualifiée.  
Le câble d'alimentation (4x1,5 H07RNF) de ce luminaire (Y) ne peut être remplacé que par une personne qualifiée.  
Il convient que le luminaire soit positionné de telle manière que le regard prolongé du luminaire à une distance <1m ne soit pas attendu.

**ENG** The light source fitted in this luminaire shall only be replaced by a Rohl employee or agent or a similar qualified person.  
The external flexible cable (4x1,5 H07RNF) of this luminaire (Y) shall only be replaced by a qualified person.  
The luminaire with clear optic should be positioned so that prolonged staring into the luminaire at a distance <1m is not expected.

**DEU** Die eingebaute Lichtquelle in der Leuchte (Y) sollte nur von einem Rohl Mitarbeiter oder Vertreter oder einer ähnlichen qualifizierten Personen ersetzt werden.  
Der Stromkabel (4x1,5 H07RNF) der Leuchte (Y) darf nur von einer qualifizierte Person ersetzt werden.  
Die Leuchte mit klarer Optik sollte so positioniert werden, dass ein längerer Blick in die Leuchte in einem Abstand <1 m nicht zu erwarten ist.

**NLD** De lichtbron in dit verlichtingstoestel mag alleen vervangen worden door een medewerker van Rohl, agent of een gekwalificeerd persoon.  
De stroomkabel (4x1,5 H07RNF) van dit toestel mag alleen vervangen worden door een gekwalificeerd persoon.  
Om te vermijden dat iemand lang en rechtstreeks in het verlichtingstoestel zou kijken, wordt aangeraden om het te installeren op een bepaalde manier, zeker indien het zich op een afstand van minder dan 1 m bevindt.

1



ROHL S.A.S.  
1 Rue de Bruxelles, BP 50048  
F 67151 ERSTEIN Cedex  
Tél: +33(0)3 90 29 90 70 / Fax: +33(0)3 90 29 90 71

